



Sggmrs 90'

Sggmrs 90' tipi konteyner vagonumuz, 22,5 ton dingil basıncına sahip fren sistemi opsiyonel olarak klasik veya kompakt fren sistemi ile donatılabilir. Vagon 6 dingilli ve 100km/h rejimine uygundur. 10", 20", 30", 40", 45" konteyner taşımacılığı yapılabilmektedir.

Our Sggmrs 90' type container wagon has an optional brake system with 22.5 tons of axle pressure. It can be equipped with a classic or compact brake system. Wagon with 6 axles and 100km/h - 120km/h suitable for the speed regime. 10", 20", 30", 40", 45" containers can be transported.



Teknik Özellikler / Technical Specifications

Vagon tipi / Type standard design	Sggmrs
Dara / Tare	25,6 t \pm 1%
Aks yükü / Axle load	22,5 tons
Maksimum yükleme / Maximum load	109,4 t
Ray açıklığı / Track gauge	1.435 mm
Tamponlar arası uzunluk / Length buffer to buffer	29.590 mm
İki boji merkezi arası mesafe / Distance between bogie pivots	2 x 11.995 mm
Yükleme yüksekliği / Loading height	1.155 mm
Gabari kapısı / Gauge	G1
Fren sistemi / Brake system	Kompakt fren sistemi / Compact brake system
Fren konfigürasyonu / Brake configuration	MH-GP-A(K) – 3xIBB10 / MZT Wabtec
Hız rejimi / Brake regime	S (100 km/h)
Kurp yarıçapı / Minimal curve radius (Single vagon)	R 75 m
Rampa açısı / Ferry ramp angle	1°30' – R 150 m
Uluslararası kullanılabilirlik / International usability	TEN GE
Boji tipi / Bogie type	Y25Lsdi(f)-KC1 (H Type)
Teker seti / Wheelset	BA004 (22,5t), ULT25 or BA 303 (25t)
Teker Çapı / Wheel diameter	920 mm
Dingil arası mesafe / Bogie wheelbase	1800 mm
Aks kutusu / Axle box	BA182 (22,5 t) or BA386 (25 t)
Kayma plakası / Polyamide liners	Railko NF21
Sabo tipi / Brake block type	Composite K type – 1xBgu (Cosid/Jurid)

Sggmrs 90'

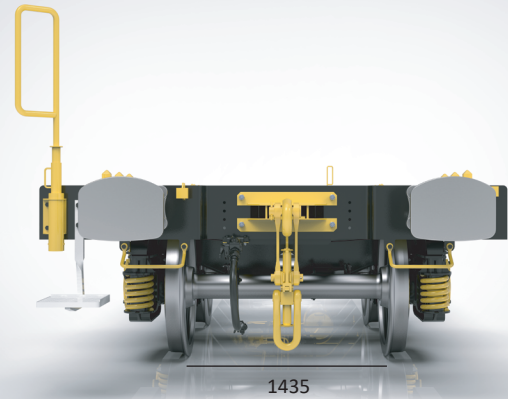
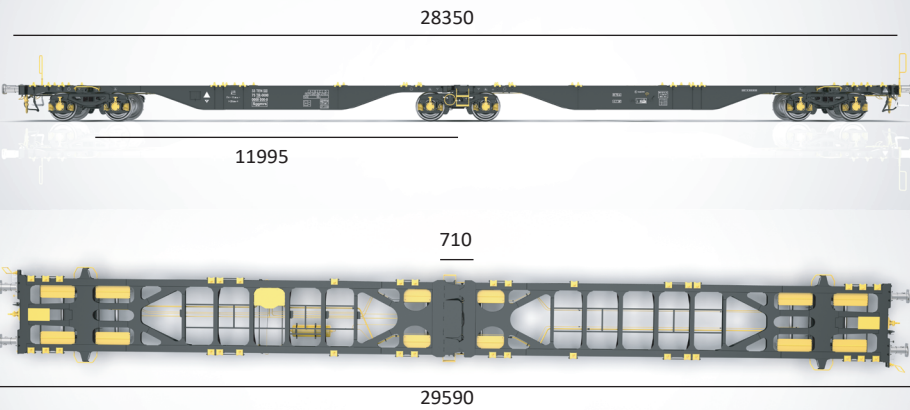

VAKO

VAGON & KONTEYNER

